

Cestari



FL series

20.500 LTS



FL SERIES 20.500 LTS



EQUIPAMIENTO STF / STF EQUIPMENT

1) Cajón Herramientas / Tool box 2) Sistema de lona enrollable / Roll Top. 3) Escaleras: trasera rebatible e interior / Leader: rear rebutable e internal; Visores de Cereal / Cereal Viewer 4) Tubo inferior desmontable / Removable lower tube 5) Boquilla de muestras / Sampling nozzle 6) Indicador Puertas Piso / Indicator hatches 7) Lubricación centralizada / Centralized Lubrication. 8) Portafaros rebatibles / Variable position lights 9) Limpieza con fondo deslizante / Cleaning system and gravity download.

Peso Tara/ Weight Tare: (*1) 4.050 kg.
Capacidad/ Capacity: (*2) 20.500 Lts.
Tiempo de descarga/ Unloading time: (*3) 2,7 min.

Llantas/ Rims: DW 20x30
Neumáticos recomendados/Tires: 23.1-30 R1 y R3
(Recomendamos / Recommended R3)

(*1): Con llantas sin neumáticos. With rims, without tires.
(*2): Sin rebase superior. Not exceed the upper edge.
(*3): Cereal seco a 540 r.p.m. Dry cereal at 540 r.p.m.

Ø Tubo/ Tube: 420 mm.
Ø Sinfín de piso/ Floor auger: 336 mm.
Ø Sinfín de tubo/ Tube auger: 396 mm.

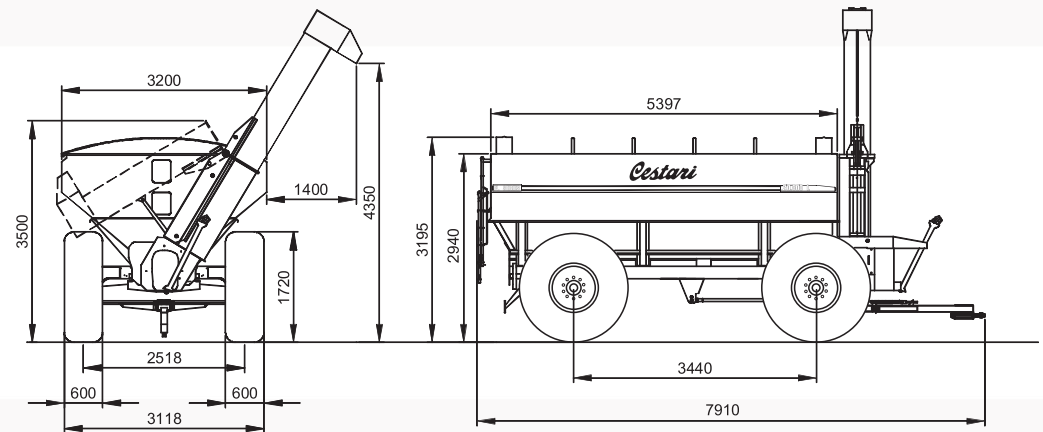

CestariTolvas



cestari tolvas



@CestariTolvas



cestaritolvas



imcestari.com



ventas@imcestari.com

VENTAS / SALES | +54 2473 430490

