

*Cestari*



**FL SERIES**

**29.000 L TS**



# FL SERIES 29.000 LTS



## EQUIPAMIENTO STF / STF EQUIPMENT

1) Cajón Herramientas / Tool box 2) Sistema de lona enrollable / Roll Top. 3) Escaleras: trasera rebatible e interior / Leader: rear rebutable e internal; Visores de Cereal / Cereal Viewer 4) Tubo inferior desmontable / Removable lower tube 5) Boquilla de muestras / Sampling nozzle 6) Indicador Puertas Piso / Indicator hatches 7) Lubricación centralizada / Centralized Lubrication. 8) Portafaros rebatibles / Variable position lights 9) Limpieza con fondo deslizante / Cleaning system and gravity download.

Peso Tara/ Weight Tare: (\*1) 6.100 kg.  
Capacidad/ Capacity: (\*2) 29.000 Lts.  
Tiempo de descarga/ Unloading time: (\*3) 3,7 min.

Llantas/ Rims: DW 21x32 o DW 27x32  
Neumáticos recomendados/Tires:  
24.5-32, 30.5L32 y 800/65-R32.

(\*1): Con llantas sin neumáticos. With rims, without tires.  
(\*2): Sin rebase superior. Not exceed the upper edge.  
(\*3): Cereal seco a 540 r.p.m. Dry cereal at 540 r.p.m.

Ø Tubo/ Tube: 480 mm.  
Ø Sinfín de piso/ Floor auger: 380 mm.  
Ø Sinfín de tubo/ Tube auger: 454 mm.

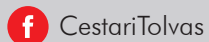
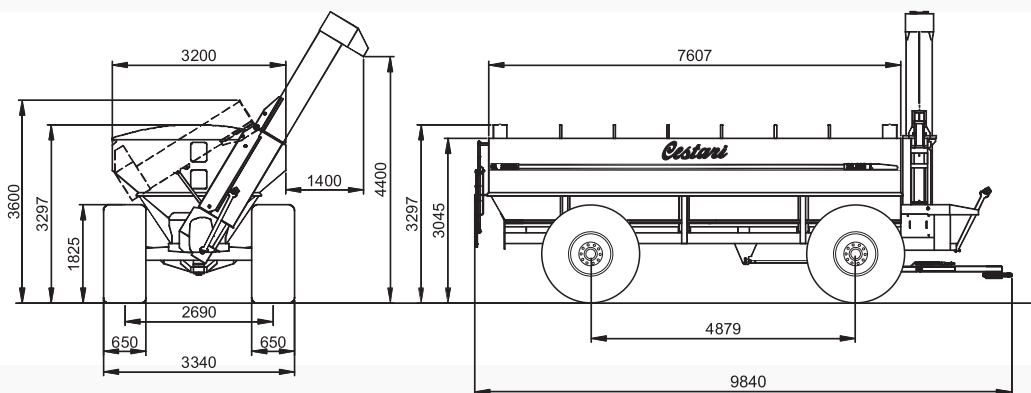

CestariTolvas



cestari tolvas



@CestariTolvas



cestaritolvas



imcestari.com



ventas@imcestari.com

VENTAS / SALES | +54 2473 430490

