

Cestari



STF SERIE

29.000 LTS



STF SERIE 29.000 LTS



EQUIPAMIENTO STF / STF EQUIPMENT

- 1) Cajón Herramientas / Tool box 2) Sistema de lona enrollable / Roll Top. 3) Escaleras: trasera rebatible e interior / Leader: rear rebutable e internal; Visores de Cereal / Cereal Viewer 4) Tubo inferior desmontable / Removable lower tube 5) Boquilla de muestras / Sampling nozzle 6) Eganche delantero con bujes amortiguadores. 7) Reflector de tubo de descarga / Reflector in discharge tray. 8) Indicador Puertas Piso / Indicator hatches 9) Limpieza con fondo deslizante / Cleaning system and gravity download. 10) Lubricación centralizada / Centralized Lubrication. 11) Portafaros rebatibles / Variable position lights 12) Eganche trasero / Removable rear hitch; Paragolpes trasero deslizante.

Peso Tara/ Weight Tare: (*1) 5.350 kg
 Capacidad/ Capacity: (*2) 28.900 Lts.
 Carga máxima / Maximum load: 26.000 kg
 Tiempo de descarga/ Unloading time: (*3) 3,3 min.
 Llantas / Rims: DW 20x30 o DW 21x32 (opcional).
 Neumáticos / Tires: 23.1-30 o 24.5-32 (opcional)
 R1 y R3 (Recomendamos R3).

Ø Tubo/ Tube: 480 mm.
 Ø Sinfín de piso/ Floor auger: 380 mm.
 Ø Sinfín de tubo/ Tube auger: 454 mm.

(*1): Con llantas sin neumáticos. With rims, without tires.
 (*2): Sin rebase superior. Not exceed the upper edge.
 (*3): Cereal seco a 540 r.p.m. Dry cereal at 540 r.p.m.

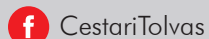
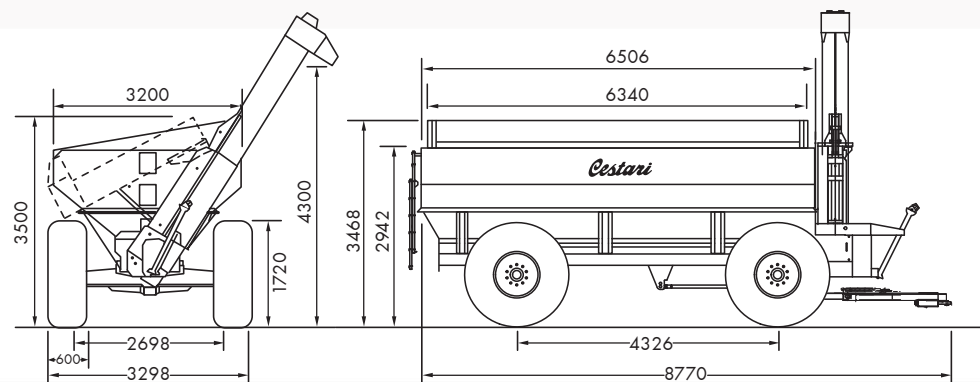

CestariTolvas



cestari tolvas



@CestariTolvas



cestaritolvas



imcestari.com



ventas@imcestari.com

VENTAS / SALES | +54 2473 430490

